

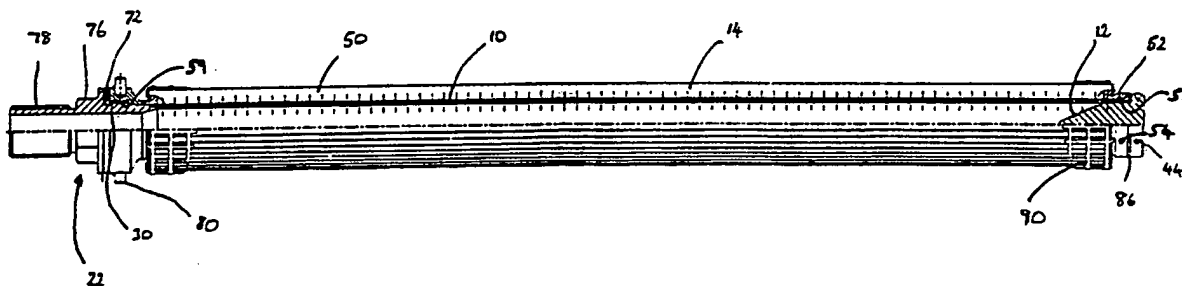

INTERNATIONAL APPLICATION PUBLISHED UNDER THE PATENT COOPERATION TREATY (PCT)

(51) International Patent Classification ⁵ : B01D 29/15	A1	(11) International Publication Number: WO 90/00434 (43) International Publication Date: 25 January 1990 (25.01.90)
<p>(21) International Application Number: PCT/GB89/00704</p> <p>(22) International Filing Date: 23 June 1989 (23.06.89)</p> <p>(30) Priority data: 8816216.9 7 July 1988 (07.07.88) GB</p> <p>(71) Applicant (for all designated States except US): FAIREY AR- LON LIMITED [GB/GB]; Cranford Lane, Heston, Hounslow, Middlesex TW5 9NQ (GB).</p> <p>(72) Inventor; and (75) Inventor/Applicant (for US only) : SEXTON, John [GB/ GB]; "Bobcat", West Street, Odiham, Hants RG25 1NR (GB).</p> <p>(74) Agents: MAGGS, Michael, Norman et al.; Kilburn & Strode, 30 John Street, London WC1N 2DD (GB).</p>	<p>(81) Designated States: AT, AT (European patent), AU, BB, BE (European patent), BF (OAPI patent), BG, BJ (OAPI patent), BR, CF (OAPI patent), CG (OAPI patent), CH, CH (European patent), CM (OAPI patent), DE, DE (European patent), DK, FI, FR (European patent), GA (OAPI patent), GB, GB (European patent), HU, IT (Eu- ropean patent), JP, KP, KR, LK, LU, LU (European pa- tent), MC, MG, ML (OAPI patent), MR (OAPI patent), MW, NL, NL (European patent), NO, RO, SD, SE, SE (European patent), SN (OAPI patent), SU, TD (OAPI patent), TG (OAPI patent), US.</p> <p>Published With international search report.</p>	

(54) Title: FILTERS



(57) Abstract

A candle for use in filtering polymer at high temperatures and pressures comprises an internal cylindrical apertured support member (10), surrounded by a cylindrical filter media element (14). At one end, the candle is sealed by trapping a crush-metal washer (72) between a flange of the support member (10) and a mounting portion (55) of the support member (10). At the other end, the candle is sealed by a removable conical volume-reducer which screws into an end cap (52) welded to the end of the filter media element (14). Both the end cap (52) and the volume reducer (12) have bores for receiving screwing and unscrewing tools, so that the volume reducer can be removed for cleaning, and replaced, without applying any torque to the filter media element (14) or the support member (10).

FOR THE PURPOSES OF INFORMATION ONLY

Codes used to identify States party to the PCT on the front pages of pamphlets publishing international applications under the PCT.

AT	Austria	ES	Spain	MG	Madagascar
AU	Australia	FI	Finland	ML	Mali
BB	Barbados	FR	France	MR	Mauritania
BE	Belgium	GA	Gabon	MW	Malawi
BF	Burkina Fasso	GB	United Kingdom	NL	Netherlands
BG	Bulgaria	HU	Hungary	NO	Norway
BJ	Benin	IT	Italy	RO	Romania
BR	Brazil	JP	Japan	SD	Sudan
CA	Canada	KP	Democratic People's Republic of Korea	SE	Sweden
CF	Central African Republic	KR	Republic of Korea	SN	Senegal
CG	Congo	LI	Liechtenstein	SU	Soviet Union
CH	Switzerland	LK	Sri Lanka	TD	Chad
CM	Cameroon	LU	Luxembourg	TG	Togo
DE	Germany, Federal Republic of	MC	Monaco	US	United States of America
DK	Denmark				

FILTERS

The present invention relates to filters and in particular to a filter of the cylindrical or candle type having a removable filter media. One specific application to which the invention may be applied is the filtration at high temperatures and pressures (for
5 example over 250°C and 10^7 Pa) of corrosive molten polymers.

Polymer candles with removable filter media are already known, for example from European patent application 90383 and United States patent 4218324. It
10 has been found, however, that because of the way in which they are sealed, candles of this type cannot be used at particularly high pressures. For example, the candle shown in EP 90383 is suitable for use only with
15 low viscosity polymers (eg solution polymers) and at low differential pressures, probably less than 2MPa.

One problem with prior art candles, particularly with the type which are cleaned by passing a back-flow of solvent through the filter media, is that there is
20 difficulty in removing solidified and/or degraded polymer from the area adjacent the volume - reducing element.

It is an object of the present invention at least to alleviate the problems of the prior art. It is a
25 further object to provide a filter candle which is suitable for use at high temperatures and pressures, and which can easily be cleaned by the back-flow of a cleaning solution.

According to the present invention there is
30 provided a filter candle having an elongate generally cylindrical apertured support member adapted for

attachment at one end thereof to an apertured mounting plate, a separate generally conical volume-reducing element arranged for removable reception in the other end of the support member and a separate elongate
5 generally cylindrical filter media member arranged for removable reception over the support member.

A filter candle of this type can easily be dismantled for cleaning, and so would be suitable for use with such difficult polymers as PEEK
10 (Polyetheretherketone).

In one embodiment, the filter media member comprises a filter media with an end cap secured thereto, and the volume-reducing element comprises a plug which is screwed into the end cap. In order that
15 an efficient seal is effected between the plug and the end cap, it is desirable that there be provided a compression seal (for example a crush-metal washer) between a flange of the plug and an end surface of the cap. Preferably, the cap is welded to the filter
20 media, and has a screwed aperture therein.

Desirably, provision is made at both ends of the filter media member for the reception or abutment of a tool whereby torque can be applied. Thus, both the end cap and the plug may each have respective means for the
25 reception or abutment of a tool, so that the end cap can be sealed against the volume-reducing element without substantial torque being applied to the filter media or the support member. In this way, the plug can be screwed on to the end of the filter candle, and
30 removed from it, while the candle is in situ on the mounting plate, without any risk of the support member or the filter media being damaged by the application of the substantial torque that is needed to seal the plug

against the high differential pressures.

The invention may be carried into practice in a number of ways, and once specific candle embodying the invention will now be described by way of example with
5 reference to the drawings, in which

Figure 1 is a partly sectioned view of an assembled candle according to an embodiment of the present invention;

Figure 2 is a longitudinal section through the
10 support member of figure 1;

Figure 3 is a side elevation of the volume reducer of figure 1; and

Figure 4 is a partly sectioned view of the removable filter media element of figure 1.

15 A partly sectioned view of a candle according to an embodiment of the present invention is shown in figure 1. The candle comprises three main parts: an apertured generally cylindrical support member 10, an exterior generally cylindrical filter media element 14,
20 surrounding the support member 10, and a conical volume reducer 12, screwed into the end of the filter media element. These three parts will now be described in more detail with reference to figures 2 to 4.

25 Figure 2 is a longitudinal section through the support member 10. The member 10 comprises an elongate cylindrical tube member 16, having a plurality of spaced apertures 18 along its length and about its circumference. To one end 20 of the tube member 16 is
30 secured by welding a mounting portion 22. The mounting portion has an internal throughbore 24 the diameter of which is generally slightly smaller than the internal diameter of the tube member 16, with a smooth transition between the two diameters being effected by

a tapered portion 25 of the bore 24.

The exterior surface of 28 of the mounting portion 22, proximate the tube member 16, is cylindrical and is flush with the exterior of the tube member 16. This surface is provided with an exterior screw-thread 30. Beyond this, there is a shoulder 31 followed by an annular mounting flange 32, and beyond that a hexagonal nut 36. Finally, at the far end of the mounting portion 22 there is an exterior screw-thread 78.

The second component of the candle, the volume reducer 12, is shown in detail in figure 3. It comprises a blunt-nosed conical portion 36 having, at its base, a cylindrical screw-threaded mounting portion 38. Behind this mounting portion there is a reduced-diameter neck 39 followed by a shoulder 40 and a flat cylindrical base portion 42. The base portion has three equidistant blind bores 44 therein, to enable the volume reducer to be grasped by a suitable tool, and torque applied.

The third component of the candle, the filter media element 14, is illustrated in figure 4. It comprises a hollow cylindrical pleated filter media 50, of a type and fineness depending upon the fluid to be filtered. Typically, the filter media will comprise stainless steel mesh enclosing randomly orientated sintered metallic fibres. Other types of filter media could, of course, be used and in certain circumstances it may not be necessary for the media to be pleated.

To one end of the filter media 50 is welded a generally cup-shaped end cap 52 having a screwed axial bore 53 therein. Equidistantly spaced in the sides of the cap 52 are three blind bores 54, for the reception of a tool whereby torque may be applied. To the other

end of the filter media 50 is welded a mounting member 55, having a throughbore 56 which is formed at its far end with an interior screw thread 59. The exterior of the mounting member 55 has a pair of diagonally-opposite pins 80 which are adapted to take an appropriate tool. Alternatively, these pins (and also the blind bores 54) could be replaced by some other means whereby the mounting can be rotated, for example a cylindrical surface with flats or a hexagonal nut. At the far end of the mounting member 55 there is an axial annular sealing surface 64.

Finally, the pleated filter media member 50 is provided with an apertured media guard 90.

Returning now to figure 1, the way in which the candle is assembled will now be described. First, the support member 10 will be screwed into a threaded aperture of a tube plate (not shown) using the screwthread 78. A crush-metal washer 72 is then passed over the end of the tube member 16 and located in the space between the shoulder 31 and the flange 32. Then, the filter media element 14 is positioned over the support member 10, and is firmly screwed down against the washer 72 using the pins 80. Thus, the washer 72 is compressed between the sealing surface 64 of the filter media element 14 and the flange 32 of the mounting portion 22, so forming a seal.

Finally, a further crush-metal washer 86 is positioned behind the shoulder 40 of the volume reducer 12, and the latter is then firmly screwed into the threaded bore 53 of the end cap 52. Conveniently, this can be done by using a suitable tool in the bores 44 of the volume reducer 12 to provide a torque, while at the same time using a similar tool in the bores 54 of the

end cap 52 to provide an equal and opposite torque. Thus, substantially no torque is transmitted either to the filter media 50 or to the support member 10. This is convenient since it means that the volume reducer
5 can be removed and replaced where necessary for cleaning without it always being essential to unscrew the support member 10 from the tube plate.

In operation, the molten polymeric material to be filtered passes from the exterior of the filter media
10 element 50 through the apertures 18 in the tube member 16, and then through the bore 24 and out of the other side of the tube plate (not shown). The shape of the volume reducer 12 is such that no stagnant areas of polymer can form.

15 It is convenient for the candle of this embodiment to be constructed (other than perhaps the fibres of the filter media itself) entirely of stainless steel.

CLAIMS

1. A filter candle having an elongate generally cylindrical apertured support member adapted for attachment at one end thereof to an apertured mounting plate, a separate generally conical volume-reducing element arranged for removable reception in the other end of the support member and a separate elongate generally cylindrical filter media member arranged for removable reception over the support member.

2. A filter candle as claimed in claim 1 in which the filter media member comprises a filter media with an end cap secured thereto, and the volume-reducing element comprises a plug which is screwed into the end cap.

3. A filter candle as claimed in Claim 2 in which the end cap is secured by welding to the filter media.

4. A filter candle as claimed in any one of the preceding claims in which the filter media member is sealed against the volume-reducing element.

5. A filter candle as claimed in Claim 4 in which the seal comprises an intermediate crush-metal washer interposed between the filter media member and the volume-reducing element.

6. A filter candle as claimed in any one of the preceding claims when dependent upon Claim 2 in which

the end cap and the plug each have respective means for the reception or abutment of a tool whereby torque may be applied so that the end cap can be sealed against the volume reducing element without substantial torque being applied to the filter media or to the support member.

7. A filter candle as claimed in any one of the preceding claims suitable for filtering molten polymers at a temperature of at least 250°C, over a pressure drop of a least 100 Bar (10^7 Pa).

8. A filter candle substantially as specifically described with reference to the drawings.

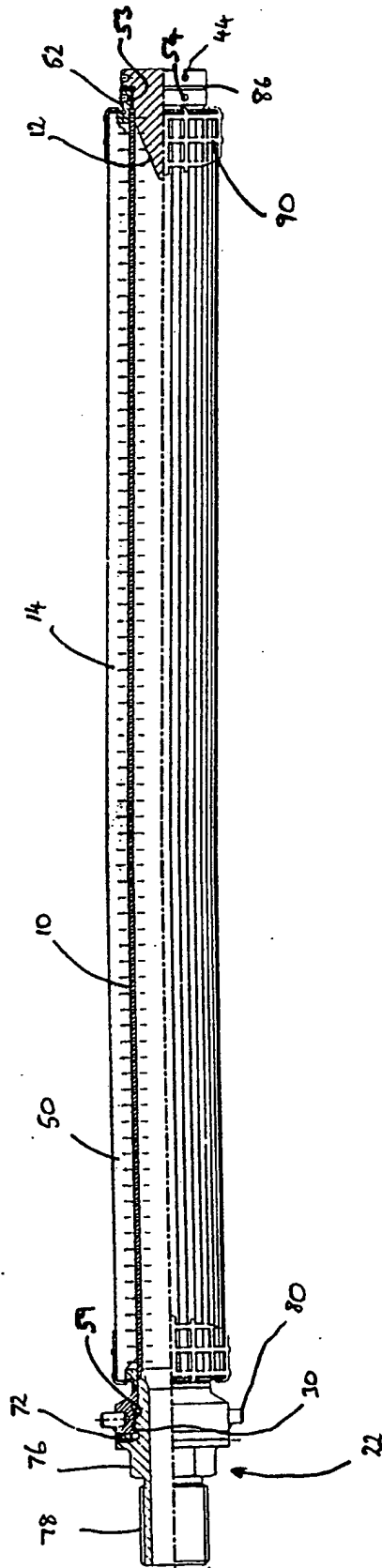

Fig 1

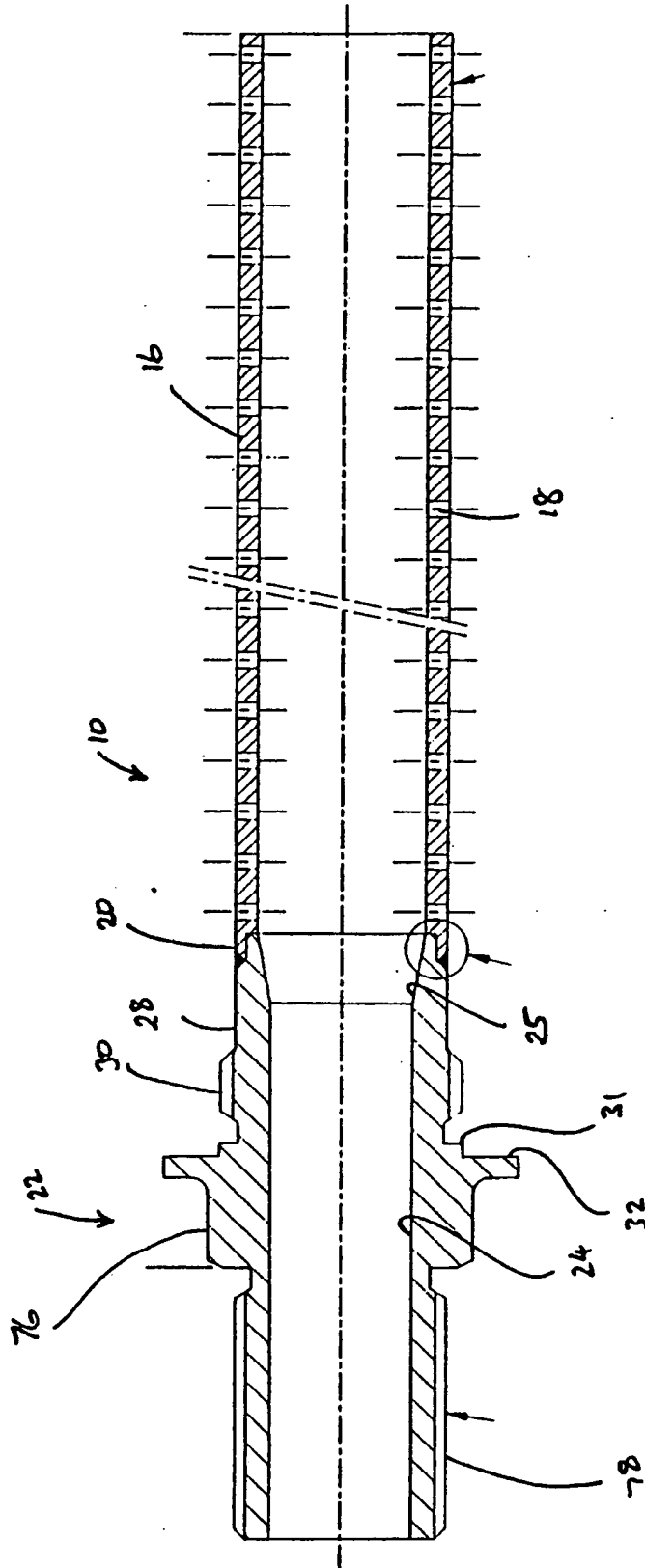

Fig 2

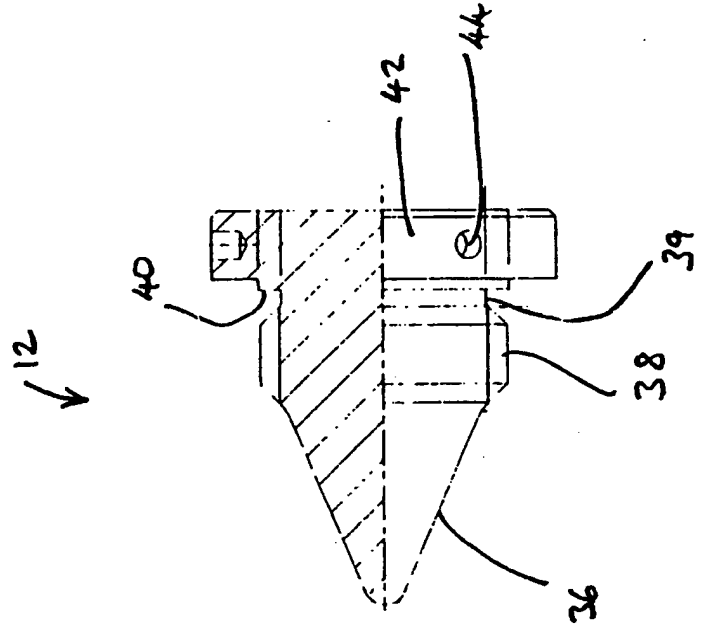

Fig 3

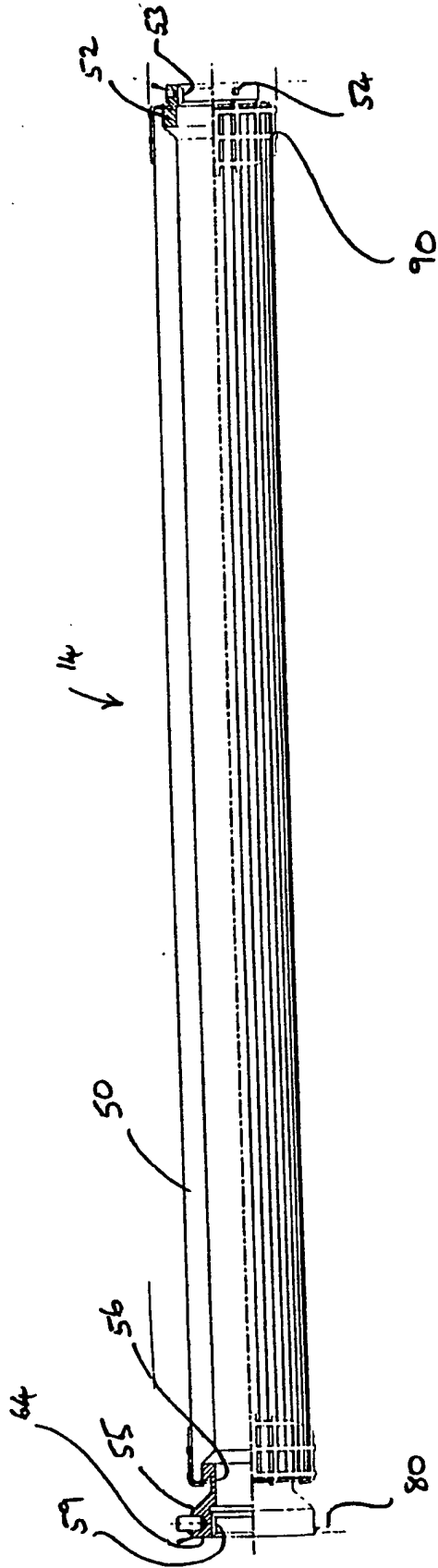
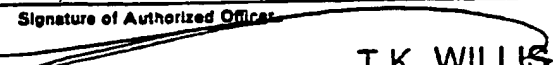

Fig 4

INTERNATIONAL SEARCH REPORT

International Application No **PCT/GB 89/00704**

I. CLASSIFICATION OF SUBJECT MATTER (if several classification symbols apply, indicate all) ⁸		
According to International Patent Classification (IPC) or to both National Classification and IPC		
IPC ⁵ : B 01 D 29/15		
II. FIELDS SEARCHED		
Minimum Documentation Searched ⁷		
Classification System	Classification Symbols	
IPC ⁵	B 01 D	
Documentation Searched other than Minimum Documentation to the Extent that such Documents are included in the Fields Searched ⁸		
III. DOCUMENTS CONSIDERED TO BE RELEVANT ⁹		
Category ⁹	Citation of Document, ¹¹ with indication, where appropriate, of the relevant passages ¹²	Relevant to Claim No. ¹³
A	US, A, 4094790 (H. SCHMIDT) 13 June 1978, see columns 2,3 --	1,5
A	EP, A, 0257009 (A-1 ENGINEERING) 24 February 1988, see column 2, lines 60-63; columns 3-6 --	1,2,7
A	US, A, 3253714 (J.J. QUINLAN) 31 May 1966, see column 4, lines 58-75; columns 5,6 --	1-3
A	US, A, 2584387 (F.B. HARVUOT) 5 February 1952, see column 4, lines 16-60 -----	1
<p>⁹ Special categories of cited documents: ¹⁰</p> <p>"A" document defining the general state of the art which is not considered to be of particular relevance</p> <p>"E" earlier document but published on or after the international filing date</p> <p>"L" document which may throw doubts on priority claim(s) or which is cited to establish the publication date of another citation or other special reason (as specified)</p> <p>"O" document referring to an oral disclosure, use, exhibition or other means</p> <p>"P" document published prior to the international filing date but later than the priority date claimed</p> <p>"T" later document published after the international filing date or priority date and not in conflict with the application but cited to understand the principle or theory underlying the invention</p> <p>"X" document of particular relevance: the claimed invention cannot be considered novel or cannot be considered to involve an inventive step</p> <p>"Y" document of particular relevance: the claimed invention cannot be considered to involve an inventive step when the document is combined with one or more other such documents, such combination being obvious to a person skilled in the art.</p> <p>"&" document member of the same patent family</p>		
IV. CERTIFICATION		
Date of the Actual Completion of the International Search	Date of Mailing of this International Search Report	
29th September 1989	24 OCT 1989	
International Searching Authority	Signature of Authorized Officer	
EUROPEAN PATENT OFFICE	 T.K. WILLIS	

**ANNEX TO THE INTERNATIONAL SEARCH REPORT
ON INTERNATIONAL PATENT APPLICATION NO.**

GB 8900704
SA 29519

This annex lists the patent family members relating to the patent documents cited in the above-mentioned international search report. The members are as contained in the European Patent Office EDP file on 18/10/89. The European Patent Office is in no way liable for these particulars which are merely given for the purpose of information.

Patent document cited in search report	Publication date	Patent family member(s)	Publication date
US-A- 4094790	13-06-78	None	
EP-A- 0257009	24-02-88	AU-A- 7666887	18-02-88
US-A- 3253714		None	
US-A- 2584387		None	

EPO FORM 10479

For more details about this annex : see Official Journal of the European Patent Office, No. 12/82